

12 11 10 9 8 7 6 5 4 3 2 1

F

E

D

C

B

A

F

E

D

C

B

A

F

E

D

C

B

A

F

E

D

C

B

A

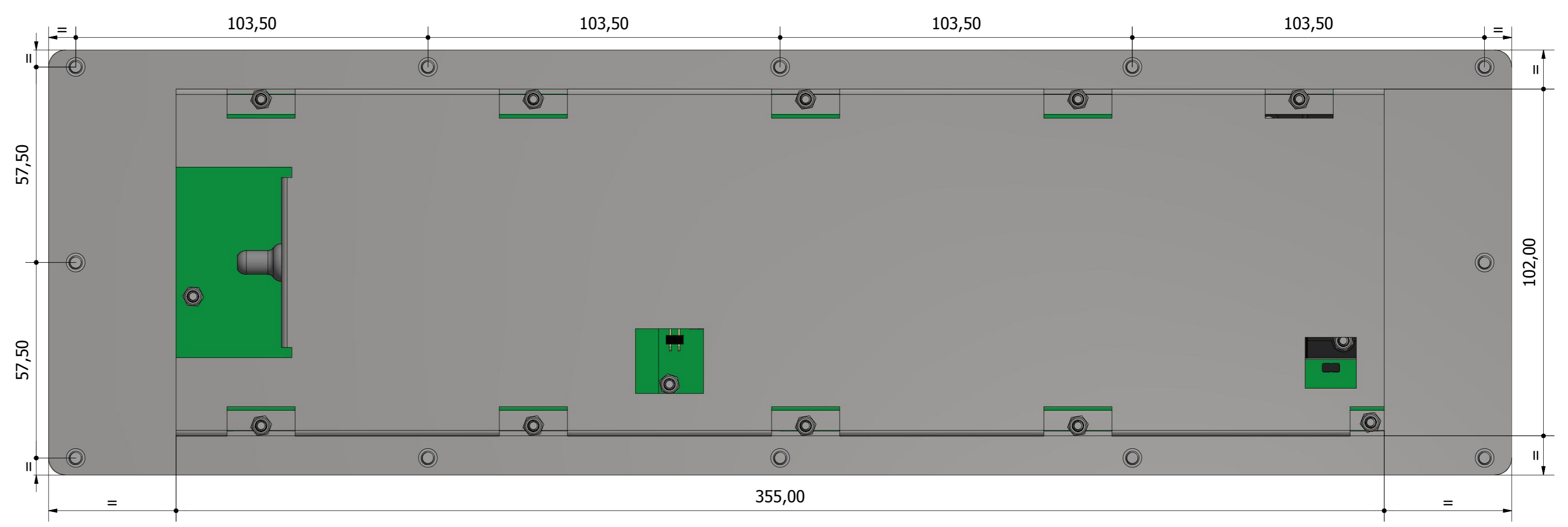
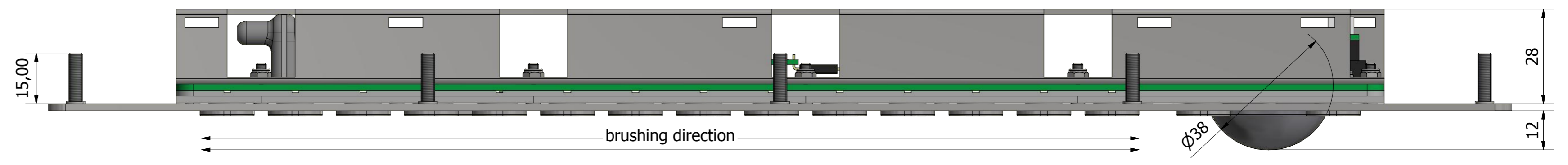
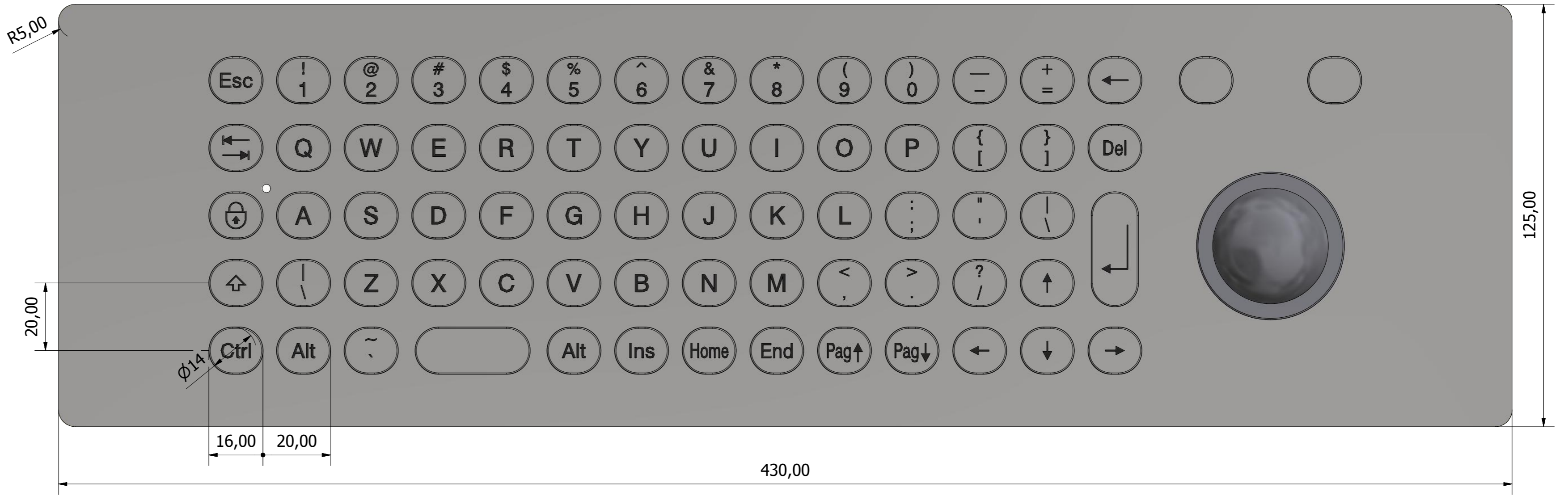
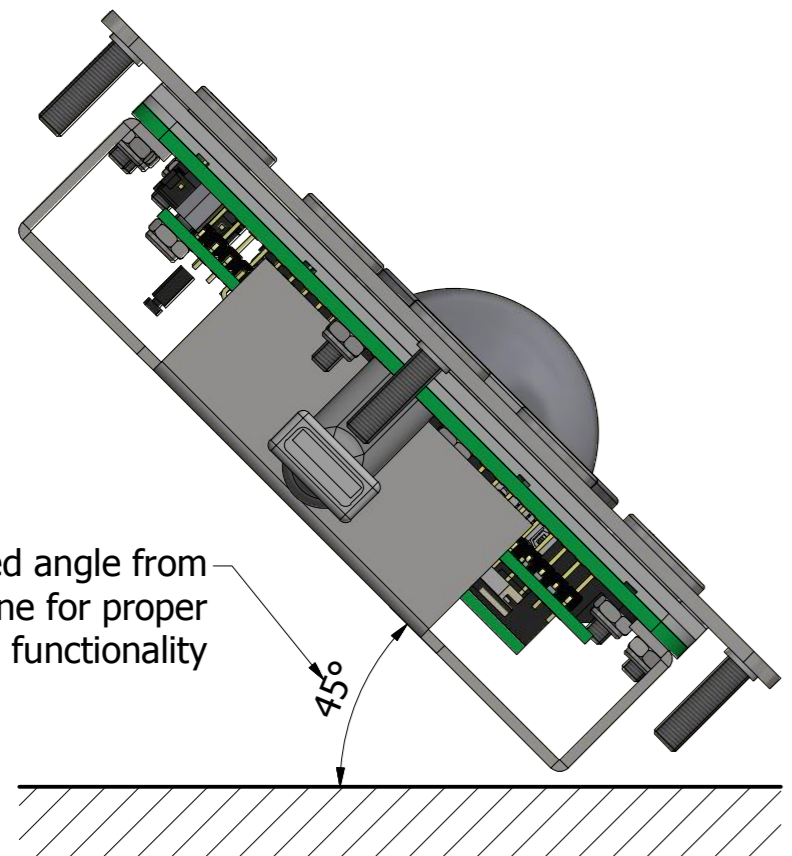

<b>Grafos Steel S.r.l.</b> Via Treves 19/21 41043 Formigine (MO) ITALY Tel. +39.059.57.50.267 www.grafossteel.it		Title: Fit Inox keyboard; 68 buttons (E16 keycap); front mount; USB+PS/2 interface; stainless steel trackball P/N: <b>FIT.68E16.F-TI</b> Dimensions without indicated tolerances - precision according to: <b>ISO 2768 F</b>		Rev: File: FIT.68E16.F-TI (Data-sheet).idw	Drawn: <b>A. Tosi</b>
Date:	28/12/2016	Tolerance class	Length (mm) >0 - 6 ±0.2 >6-30 ±0.5 >30-120 ±0.8 >120-400 ±1.2	Approved:	
Material:	-	M (medium)	±0.1	F (Fine)	±0.05
Surface treatment:	-	±0.1	±0.1	±0.15	±0.2
<b>UNLESS OTHERWISE SPECIFIED, DIMENSIONS ARE IN MILLIMETERS</b>			Sheet:	1	Of: 2

12 11 10 9 8 7 6 5 4 3 2 1



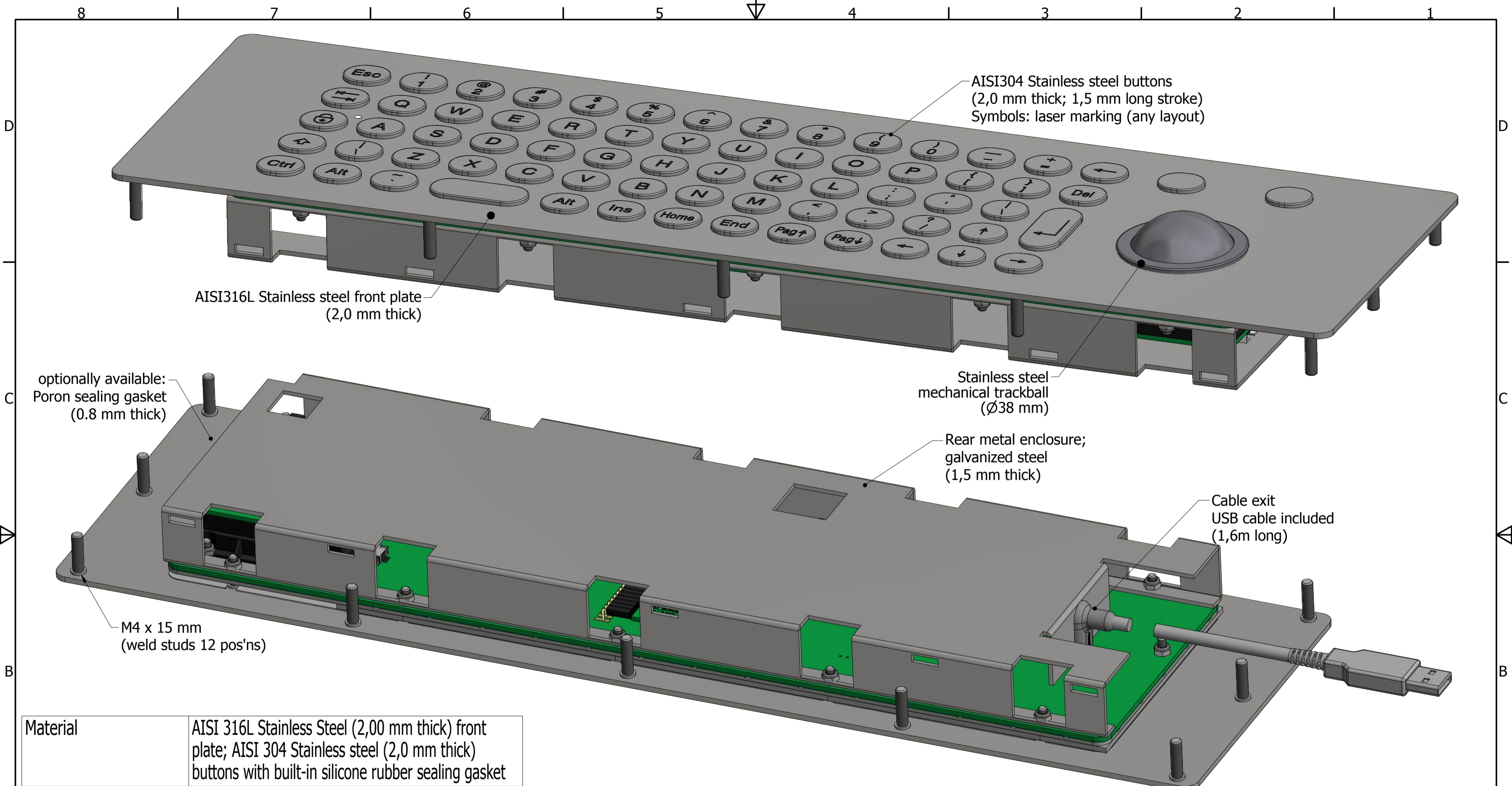

Material	AISI 316L Stainless Steel (2,00 mm thick) front plate; AISI 304 Stainless steel (2,0 mm thick) buttons with built-in silicone rubber sealing gasket
Lettering	Laser marking (any layout)
Button stroke	1,5 mm +/- 0,1 mm
Actuation force	1,5 N (typical)
Life expectancy	>2.000.000 cycles
IP Protection rate	IP65 (when ball is stationary); IP54 (when ball is rotating)
Impact Protection Rate	IK08
Contact technology	Conductive carbon pill on Gold plated PCB
Connection	USB
Operating temperature	0°/+50°C
Storage temperature	-25°/+55°C

<b>Grafos Steel S.r.l.</b> Via Treves 19/21 41043 Formigine (MO) ITALY Tel. +39.059.57.50.267 www.grafossteel.it		Title: Fit Inox keyboard; 68 buttons (E16 keycap); front mount; USB+PS/2 interface; stainless steel trackball	
P/N: <b>FIT.68E16.F-TI</b>		Rev:	File: FIT.68E16.F-TI (Data-sheet).idw
Date: 28/12/2016		Dimensions without indicated tolerances - precision according to: <b>ISO 2768 F</b>	
Material:	Surface treatment:	Tolerance class	Lenght (mm)
-	-	>0 - 6	>6-30
		>30-120	>120-400
		C (Coarse)	±0.2
		M (medium)	±0.1
		F (Fine)	±0.05
		±0.5	±0.8
		±0.2	±0.3
		±0.1	±0.5
		±0.15	±0.2
		Drawn:	A. Tosi
		Approved:	
Sheet:	Of:	Sheet: 2 Of: 2	

UNLESS OTHERWISE SPECIFIED, DIMENSIONS ARE IN MILLIMETERS