



Master Touch

Data Sheet

DGI.16Q12.F

Tastiera 16 tasti quadrati ø12 montaggio fronte pannello
Front mounting 16 square ø12 keys keyboard



IP	65 (54 with TI)
IK	08
Cycles	3.000.000
Operating temp.	-10° to +70°C (0° to +50°C with TI)
Storage temp.	-25° to +85°C (-25° to +55°C with TI)



Quick web link



www.grafossteel.it

Disegni Drawings

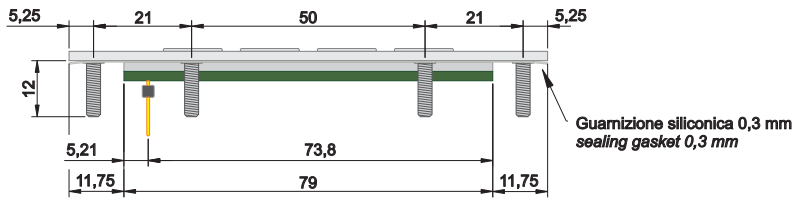

Nr. 8 M3x12 mm

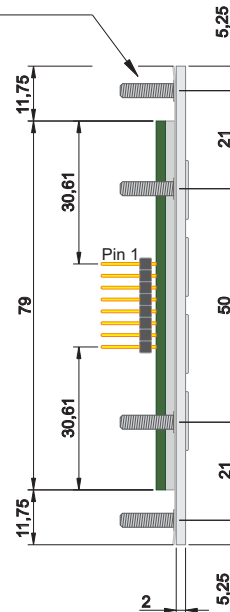
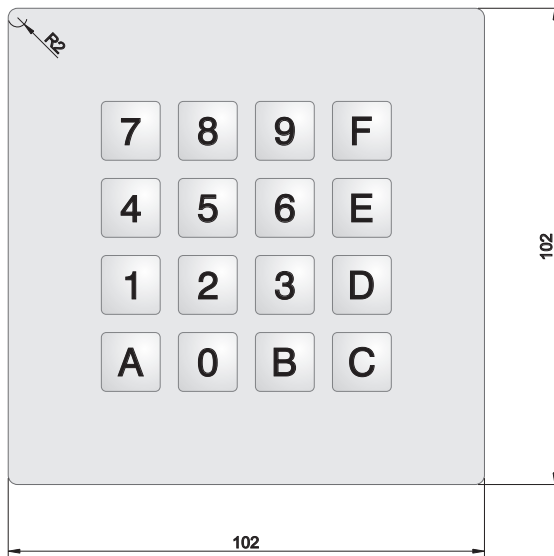

Pin-Out

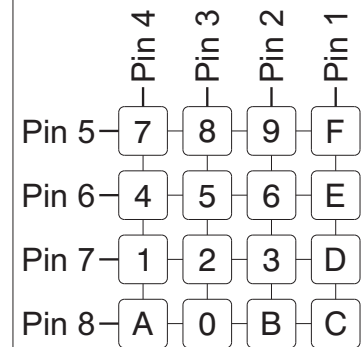

Cutout consigliato Suggested Cut-out

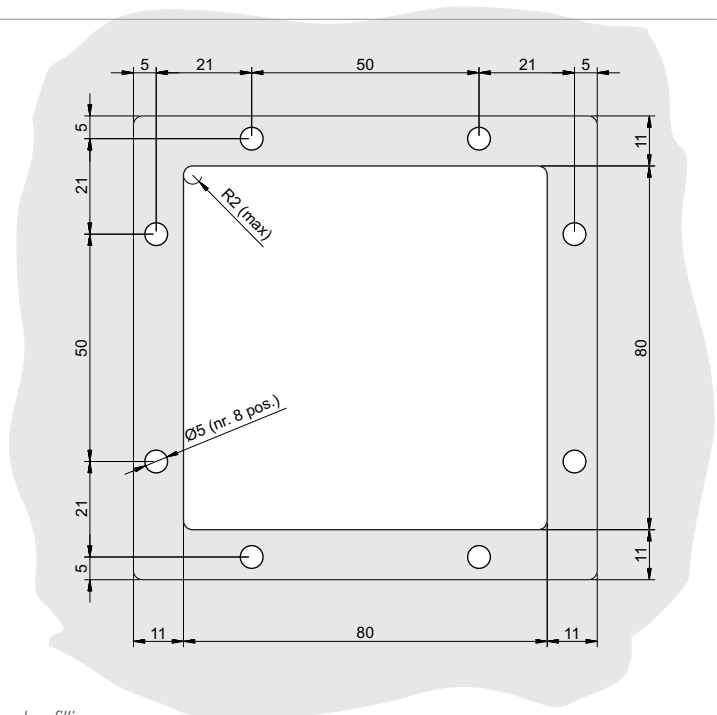

Codifica per l'ordine

DGI.16Q12.F-C



Marcatura Simboli / Marking Type

C - Incisione chimica + colore / Chemical engraving + color filling